

Empire Pendant Lamp

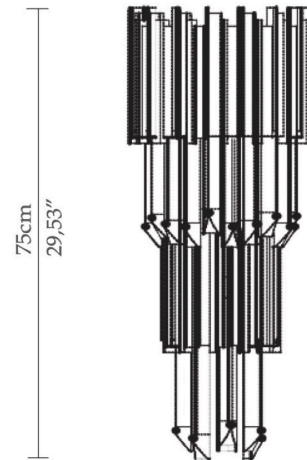
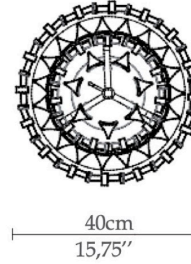

DIMENSIONS

Cord Height: Adjustable with
200cm | 78,74"

Height: 75cm | 29,53"

Diameter: 40cm | 15,75"

MATERIALS

Body: Brass & Crystal Glass

STANDARD FINISHES

Body: Gold plated

WEIGHT

Aprox: 18kg | 39,68lbs

BULBS

6x g9 Halogen Bulbs (40W
max)*USA not included

Voltage: 220-240V

PACKAGING

Volume: 0,1392 m³ | 4,9158 ft³